

Cyclone separator DF-C

The cyclone separator for the removal of solid and liquid particles and aerosols from compressed air and gases.

Product description:

The cyclone separators DF-C are designed for the processing of compressed air or other gases in industrial applications.

The units offer a high degree of separation over a large flow range with small pressure losses.

This is ensured by an innovative spin insert and a flow-optimised design of the housing.

This product series DF-C offers 7 different housings with a flow range between 50 and 1100 m³/h (related to 7 bar (g)).

The cyclone separator is conform to the requirements of the European directive 97/23/EG for pressure vessels.



Two versions are available:

Standard

Type with time controlled condensate drain UFZ

Superplus

Type with level-controlled condensate drain UFM-D

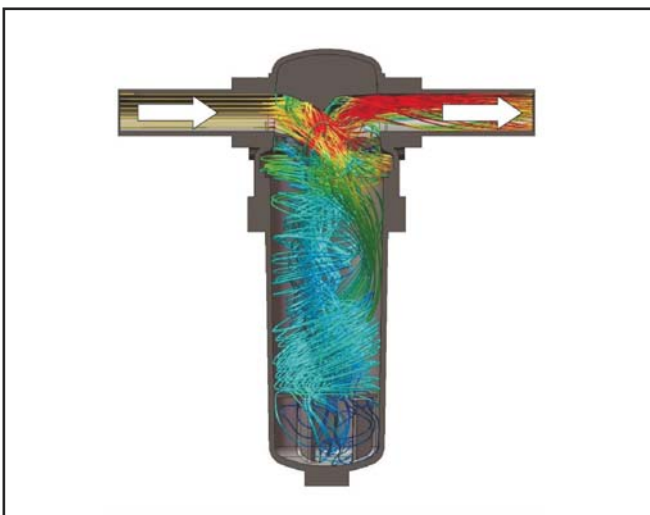

Function description:

Through the innovative insert in the cyclone head the inlet air flow is moved into a fast rotating drive, which centrifuges larger particles due to their mass inertia against the inner housing wall. Through friction with the housing the particles lose part of their kinetic energy and slide down with reduced speed towards housing ground. The collected condensate on the housing ground is removed via condensate drain, while the purified compressed air is made available to the system.

DF-C 0050 - DF-C 1100

Technical Data

Features:	Benefits:
Flow-optimised design of the housing	Low pressure losses, thereby saving energy costs
Innovative spin insert	High retention rates over a large volume flow range
Intelligent overall concept	Series range, retention rates and available options perfectly meet requirements of industrial air purification. Adequate to the industrial filter series DF
Bayonet fixing between housing head and housing bowl	Easy to use construction, simple inspection and cleaning of the housing
Housing cannot be opened under pressure due to bayonet lock	High safety during operation
Housings immersion-laquererd on the inside and outside surface	Long-term corrosion protection, also against aggressive condensates

Options:	
UFM-D	Electronic level-controlled condensate drain without compressed air losses
UFZ	Time-controlled condensate drain
Wall bracket	Distance to the wall gradelessly adjustable
Connection adapter	Intelligent adapter solution for filter combination

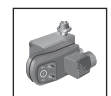
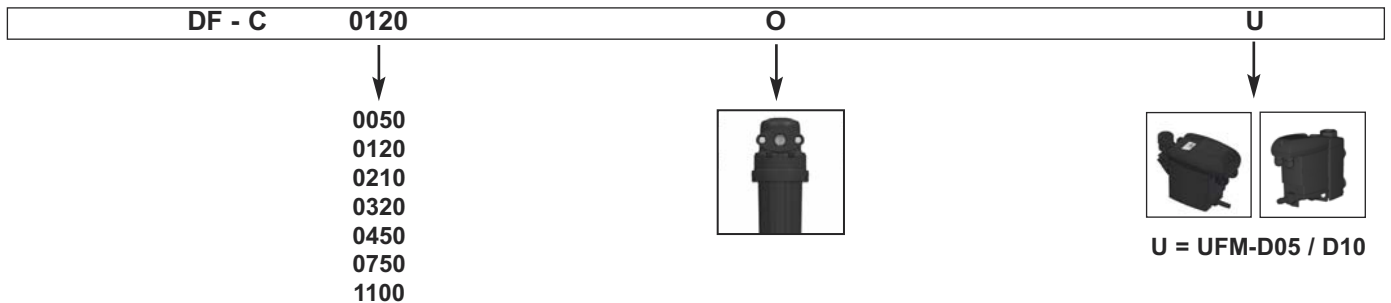

T = UFZ

Cyclone Separator DF-C Differential Pressures			
No.	Cyclone type	Nominal flow m ³ /h ¹⁾	Δp ²⁾ mbar
1	0050	50	95
2	0120	120	60
3	0210	210	50
4	0320	320	65
5	0450	450	40
6	0750	750	55
7	1100	1100	70

Full retention rate related to 8 bar a:	
≥ 5 μm	99%
≥ 10 μm	100%

¹⁾ Volume flow related to 1 bar (absolute) / 20°C

²⁾ Differential pressure related to 8 bar (absolute) operating pressure

DF-C 0050 - DF-C 1100 Standard

Pos.	Piece	Description
1	1	Housing head
2	1	Housing bowl
3	2	Wall bracket (option)
4	1	Drain UFZ

Materials	
Filter housing	Aluminium die cast
Float drain	Brass
Sealings	Viton / NBR

Max. operating pressure	16 bar
Test pressure	22.9 bar
Perm. operating temperature	+1°C / +65°C

Classification acc. to 97 / 23 / EG for fluids group 2	
DF-C 0050 - DF-C 0320	Art. 3, par. 3
DF-C 0450 - DF-C 1100	Cat. I

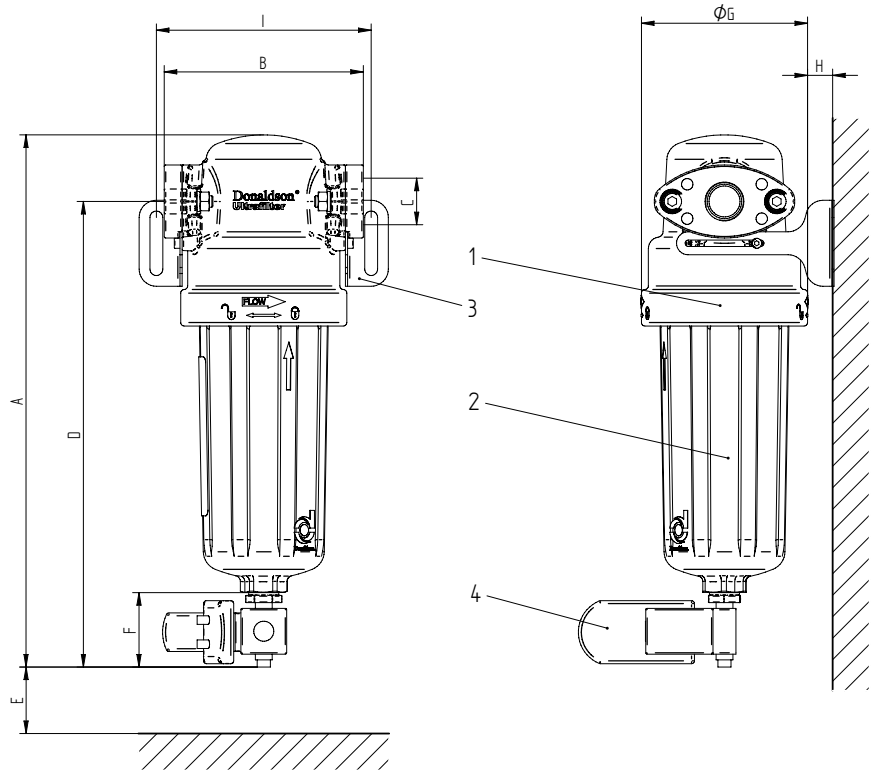

Size	Flow rate* m ³ /h	Volume (l)	Weight (kg)	A mm	B mm	C	D mm	E mm	F mm	Ø G mm	H min./ max. mm	I mm
0050	50	0,28	0,78	243,5	76	G 3/8	211,0	50	52	66	16,0	84
0120	120	0,56	1,12	286,0	103	G 1/2	246,5	50	52	85	14,5 / 45,0	107
0210	210	1,47	2,18	371,5	139	G 3/4	325,0	60	52	116	15,5 / 66,0	150
0320	320	1,47	2,18	371,5	139	G 1	325,0	60	52	116	15,5 / 66,0	150
0450	450	5,42	5,32	575,5	190	G 1 1/2	512,5	70	52	160	25,0 / 95,0	190
0750	750	5,42	5,32	575,5	190	G 2	512,5	70	52	160	25,0 / 95,0	190
1100	1100	5,42	5,32	575,5	190	G 2	512,5	70	52	160	25,0 / 95,0	190

* Nominal flow at 7 bar g, m³/h related to 1 bar abs. and 20°C

DF-C 0050 - DF-C 1100 Superplus

Pos.	Pcs.	Description
1	1	Housing head
2	1	Housing bowl
3	2	Wall bracket (option)
4 DF-C 0050 - DF-C 0320	1	Condensate drain UFM-D05
5 DF-C 0450 - DF-C 1100	1	Condensate drain UFM-D10

Materials	
Filter housing	Aluminium die cast
UFM-D	Aluminium / fiber-glass reinforced plastic
Sealings	Viton / NBR

Max. operating pressure	16 bar
Test pressure	22.9 bar
Perm. operating temperature	+1°C / +65°C

Classification acc. to 97 / 23 / EG for fluids group 2	
DF-C 0050 - DF-C 0320	Art. 3, par. 3
DF-C 0450 - DF-C 1100	Cat. I

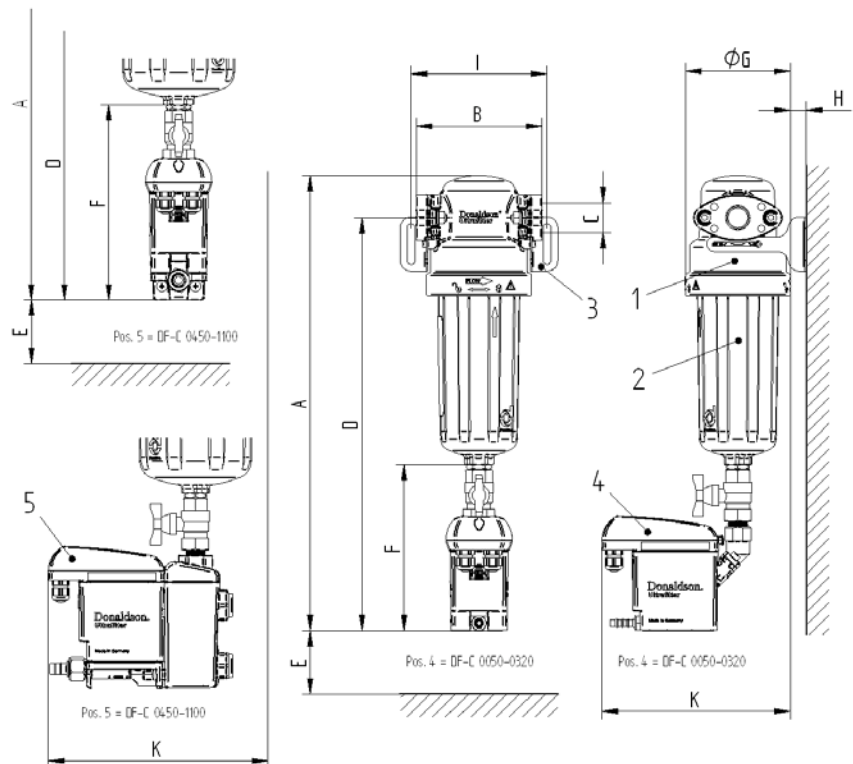

Size	Flow rate* m ³ /h	Volume (l)	Weight (kg)	A mm	B mm	C mm	D mm	E mm	F mm	G mm	H min./ max. mm	I mm	K mm
0050	50	0,28	1,34	375,0	76	G 3/8	342,5	70	183,5	66	16,0	84	183,0
0120	120	0,56	1,68	417,5	103	G 1/2	378,5	70	183,5	85	14,5 / 45,5	107	193,0
0210	210	1,47	2,74	503,0	139	G 3/4	456,5	70	183,5	116	15,5 / 66,0	150	208,0
0320	320	1,47	2,74	503,0	139	G 1	456,5	70	183,5	116	15,5 / 66,0	150	208,0
0450	450	5,42	5,88	739,0	190	G 1 1/2	676,0	70	215,5	160	25,0 / 95,0	190	242,5
0750	750	5,42	5,88	739,0	190	G 2	676,0	70	215,5	160	25,0 / 95,0	190	242,5
1100	1100	5,42	5,88	739,0	190	G 2	676,0	70	215,5	160	25,0 / 95,0	190	242,5

* Nominal flow at 7 bar g, m³/h related to 1 bar abs. and 20°C