

Silicone free Filter Housing SG Standard silicone free

The silicone free steel filter housings are designed for the industrial purification of compressed air and gases of paint compatible filter elements used in paint applications.

Product description:

The silicone free SG filter housings were designed especially for applications in the paint industry – paint compatible.

The filter housings are free from substances that could cause defects in the paint and guarantees that solid particles that could cause contamination are deposited from the compressed air and gases.

Due to an optimised construction the housings offer low differential pressures at high flow rates. A multitude of various housings with different connections, allow to match the requirements of the application, e.g. the compressor size.

This product series offers 13 different housings ranging from a volume flow of 1080 to 38400 m³/h (related to 7 bar (g) and 20°C)

The SG standard filter housing conforms to the requirements of the European directive 87/404/EG for simple pressure vessels.



Technical Data

Materials:	
Filter housing, EG-type approval	Steel
Econometer: differential gauge	Plastic
Pneumatic drain	Aluminium
Sealing acc. to DIN 2690	Aramide fibers

Maximum operating pressure:	
0108 - 0288	16 bar
0432 - 3840	16 bar

Maximum operating temperature:
120°C

Surface finish:
Polyester resin coating

Connection IN/OUT:
Flange DN 50 to DN 300; DIN 2633

Industrial filter SG 0108-0288 silicone free

Pos.	Piece	Description
12	1	knurled nut
11	1	anchor bolt
10	1	lifting eye bolt
9	1	washer
8	1	hexagon nut
7	1	hexagon bolt
6	1	drain UFM-P
5	1	econometer
4	1	filter element
3	1	housing gasket
2	1	lower housing bowl
1	1	upper housing bowl

Max. operating pressure:	16 bar
Test pressure:	24 bar
Max. operating temperature:	120°C
Material:	carbon steel
Paint coat:	polyester resin coating

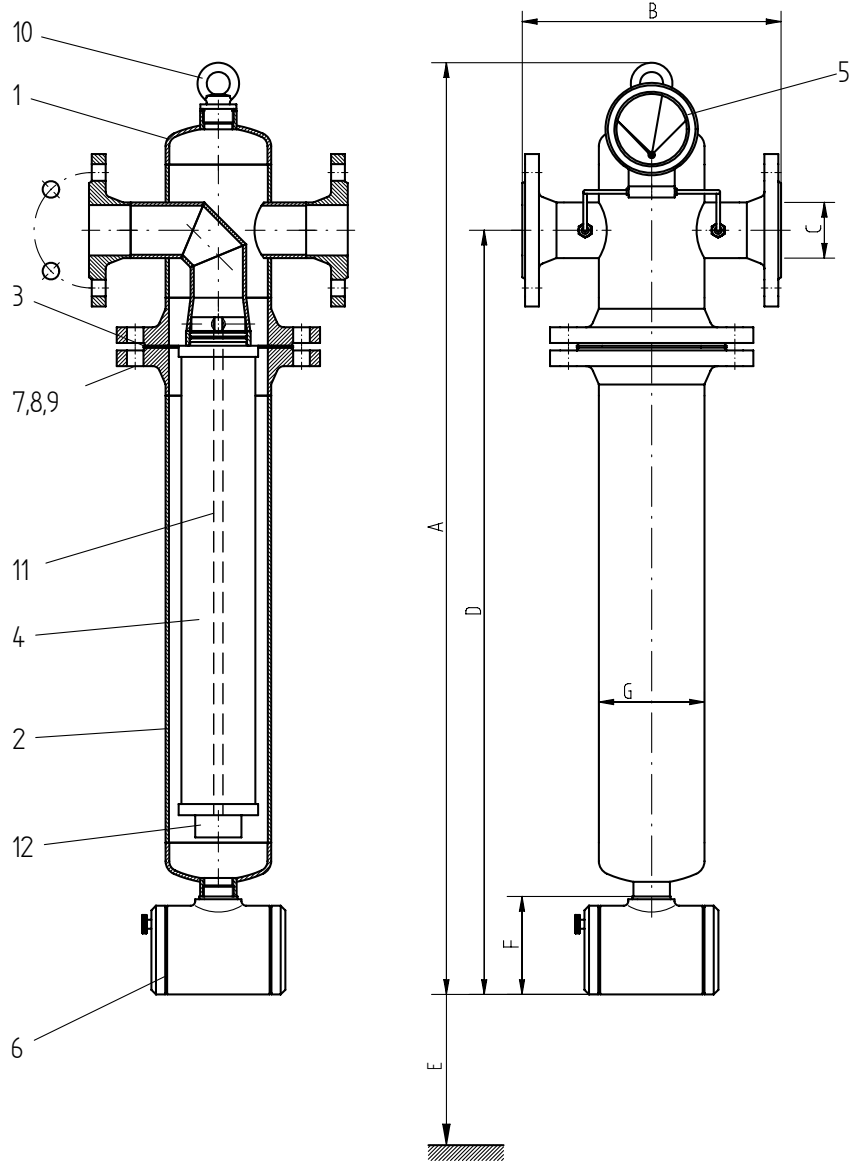

Size	Volume (l)	Weight* (kg)	A mm	B mm	C DIN 2633	D mm	E mm	F mm	ø G mm	Element
0108	7,5	28	1015	280	DN 50	830	450	105	114,3	15/30
0144	8,0	33	1015	280	DN 65	830	580	105	114,3	20/30
0192	16,0	40	1315	320	DN 80	1120	850	105	139,7	30/30
0288	23,5	54	1350	360	DN 80	1135	850	105	168,3	30/50

* without filter element

Industrial filter SG 0432-3840 silicone free

Pos.	Description
12	knurled nut
11	anchor bolt
10	lifting eye bolt
9	washer
8	hexagon nut
7	hexagon bolt
6	drain UFM-P
5	economizer
4	filter element
3	housing gasket
2	lower housing bowl
1	upper housing bowl

Max. operating pressure:	16 bar
Test pressure:	24 bar
Max. operating temperature:	120°C
Material:	carbon steel
Paint coat:	polyester resin coating

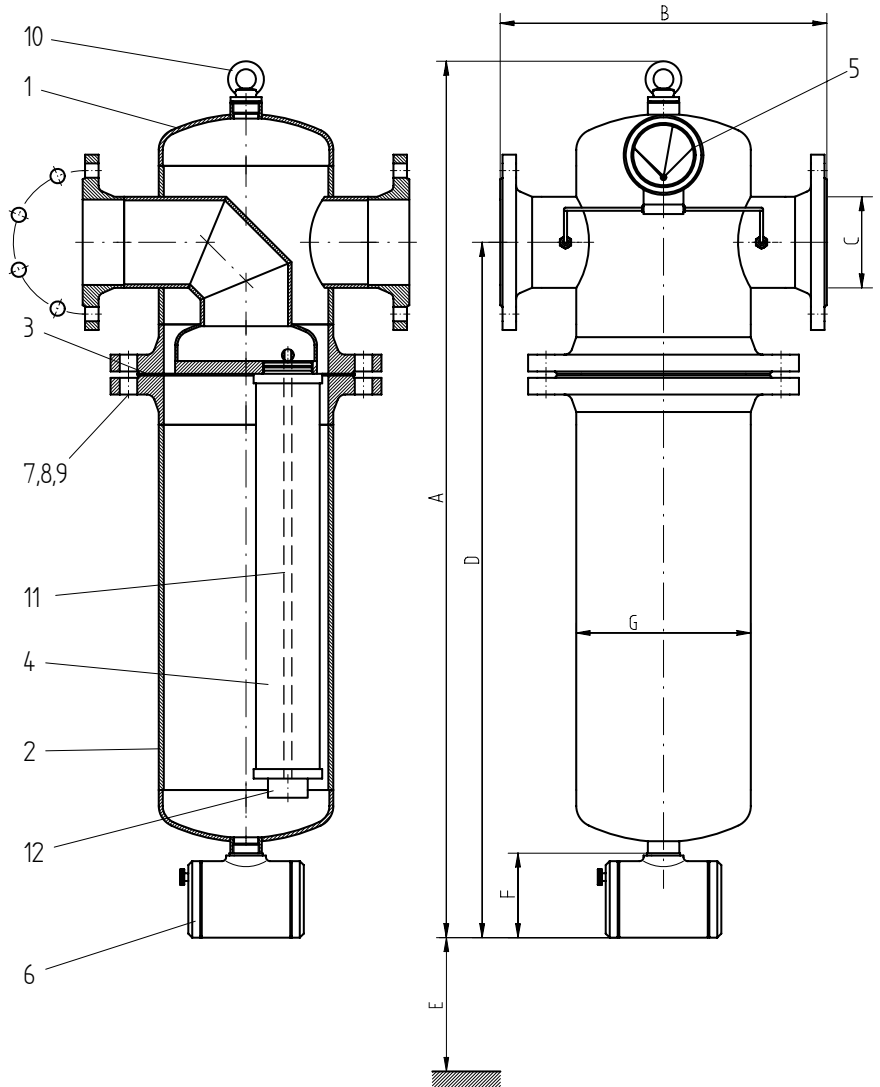

Size	Volume (l)	Weight* (kg)	A mm	B mm	C DIN 2633	D mm	E mm	F mm	ø G mm	Element
0432	31	80	1100	410	DN 100	870	580	105	219.1	3x20/30
0576	40	90	1370	410	DN 100	1140	850	105	219.1	3x30/30
0768	70	130	1485	480	DN 150	1210	875	105	273	4x30/30
1152	103	150	1510	540	DN 150	1225	875	105	323.9	6x30/30
1536	168	236	1625	660	DN 200	1285	875	105	406.4	8x30/30
1920	168	240	1625	660	DN 200	1285	875	105	406.4	10x30/30
2304	312	376	1730	800	DN 250	1350	875	105	508	12x30/30
3072	312	380	1730	800	DN 250	1350	875	105	508	16x30/30
3840	463	530	1870	930	DN 300	1445	900	105	600	20x30/30

* without filter element